

UNIQUELY DESIGNED FOR YOUR HOME

Aritco HomeLift

Datasheet 2019

We know every home is unique, and your home is a special place for you. You have picked every colour, every piece of furniture and every bit of decoration to create a home that is designed for your family, for your life and for your comfort.

Aritco HomeLift is designed to be that extra feature of your home. It is decorative and is a spectacular design feature, which makes your home unique. It provides you with that extra feeling of luxury, and it ignites the full potential of your home.

For more information please visit aritco.com

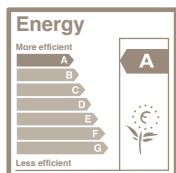

ARITCO™

Certified partner:

Landmark Lifts 

Landmark Lifts, Nova House, 162 Pratling Street, Aylesford, Kent, ME20 7DH, United Kingdom
t: 0845 8888 767 e: info@landmarklifts.co.uk w: www.landmarklifts.co.uk

Landmark Lifts is a trading name of N L C Nova Lift Co. Limited, a private limited company registered in England and Wales with company number 03423173 whose registered office address is Nova House, 162 Pratling Street, Aylesford, Kent, ME20 7DH. VAT No: 725 5204 53. **Part of the NLC Nova Group**

ARITCO HOMELIFT

DESIGNLIGHT

CARRIER AND CONTROL PANEL

The carrier consists of the L-shaped platform and a DesignWall that moves up and down when you travel in the lift. The lift is controlled from the control panel in the middle of the DesignWall. By turning and pushing the unique SmartControl on the control panel, you choose the floor and start the journey.

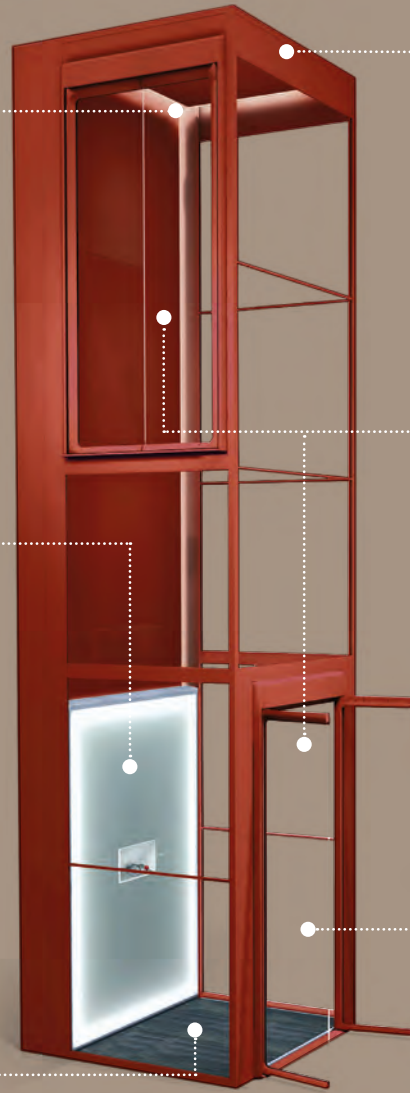

LIFT COLOUR



DOORS

Doors are installed in the lift walls on each floor. The doors are double doors, i.e. two leaves with a central opening. The door leaves are made of glass with painted profiles.

LIFT FLOOR



LIFT GLASS

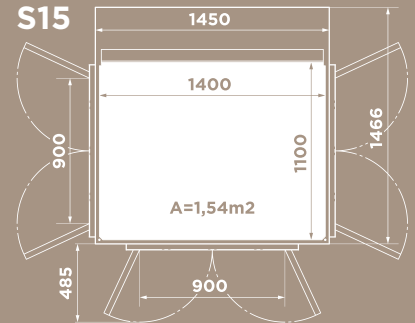

Size: 1100x1400 mm
Rated load: 400 kg / 5 pers.

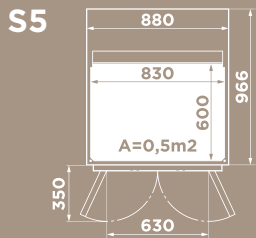

Size: 600x830 mm
Rated load: 250 kg / 2 pers.

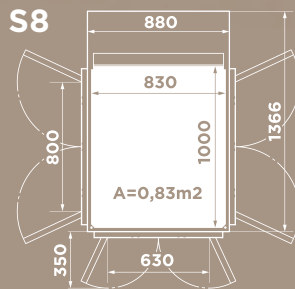

Size: 1000x830 mm
Rated load: 250 kg / 3 pers.

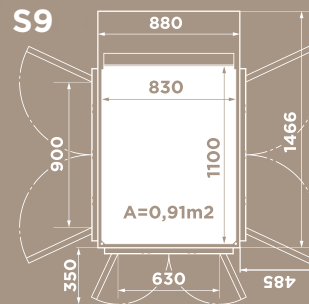

Size: 1100x830 mm
Rated load: 250 kg / 3 pers.

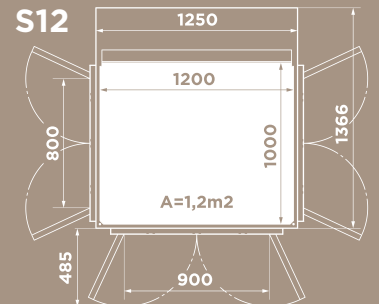

Size: 1000x1200 mm
Rated load: 400 kg / 5 pers.

Product summary

<p>TOP HEIGHT</p> <p>Minimum 2225 to 4000 mm</p>	<p>TYPE OF LIFT</p> <p>Home lift intended for installation in private homes. Only to be used in buildings without public access.</p>	<p>RATED SPEED</p> <p>Max 0,15 m/s inside Europe Max 0,30 m/s outside Europe</p>	<p>DRIVE SYSTEM</p> <p>Patented screw and nut system</p>	<p>CONTROL FROM CARRIER CONTROL PANEL</p> <p>Hold to run - press and hold For installations outside Europe - One touch operation (press one time)</p>	<p>NUMBER OF FLOORS</p> <p>2 to 6 floors</p>
<p>INSTALLATION</p> <p>Recessed installation 37 mm below floor Installed directly on the floor with a ramp</p> <p>Power supply: 230 V 1-phase 400 V 3-phase</p>	<p>INDOOR INSTALLATION ENVIRONMENT</p>	<p>TRAVEL HEIGHT</p> <p>250-15 000 millimeter</p>		<p>WARRANTY</p> <p>Aritco HomeLift comes with a 24 month warranty. The screw and nut assembly has a 10 year warranty.</p>	<p>TECHNICAL COMPLIANCE</p> <p>European Machine directive 2006/42/EC European standard EN 81-41</p>